

INTERNATIONAL STANDARD

ISO 7061

Second edition
1993-05-15

Shipbuilding Aluminium shore gangways for seagoing vessels

Construction navale — Planchons en aluminium pour navires de haute mer



Reference number
ISO 7061:1993(E)

Foreword

ISO (the International Organization for Standardization) is a worldwide federation of national standards bodies (ISO member bodies). The work of preparing International Standards is normally carried out through ISO technical committees. Each member body interested in a subject for which a technical committee has been established has the right to be represented on that committee. International organizations, governmental and non-governmental, in liaison with ISO, also take part in the work. ISO collaborates closely with the International Electrotechnical Commission (IEC) on all matters of electrotechnical standardization.

Draft International Standards adopted by the technical committees are circulated to the member bodies for voting. Publication as an International Standard requires approval by at least 75 % of the member bodies casting a vote.

International Standard ISO 7061 was prepared by Technical Committee ISO/TC 8, *Shipbuilding and marine structures*.

This second edition cancels and replaces the first edition (ISO 7061:1983), which has been technically revised.

© ISO 1993

All rights reserved. No part of this publication may be reproduced or utilized in any form or by any means, electronic or mechanical, including photocopying and microfilm, without permission in writing from the publisher.

International Organization for Standardization

Case Postale 56 • CH-1211 Geneve 20 • Switzerland

Printed in Switzerland

Shipbuilding — Aluminium shore gangways for seagoing vessels

1 Scope

This International Standard specifies requirements for aluminium shore gangways. It does not apply to gangways for inland navigation vessels.

1.1 This International Standard applies to gangways designed to be carried on board ships, to provide a lightweight, convenient and safe means of access from ship to shore, for use primarily by the ship's crew. These gangways may also be used for access from ship to ship when conditions are favourable.

1.2 This International Standard applies to gangways suitable for use horizontally or inclined up to an angle of 30° from the horizontal. For angles of inclination greater than 30°, special consideration of the design of treads and decking may be necessary.

1.3 The gangways to which this International Standard applies are not intended to carry wheeled traffic such as loaded trolleys.

NOTE 1 Users of this International Standard, while observing the requirements of the standard, should at the same time ensure compliance with any statutory requirements, rules and regulations applicable to the individual ship concerned.

2 Normative references

The following standards contain provisions which, through reference in this text, constitute provisions of this International Standard. At the time of publication, the editions indicated were valid. All standards are subject to revision, and parties to agreements based on this International Standard are encouraged to investigate the possibility of applying the most recent editions of the standards indicated below. Members of IEC and ISO maintain registers of currently valid International Standards.

ISO 209-1:1989, *Wrought aluminium and aluminium alloys — Chemical composition and forms of products — Part 1: Chemical composition.*

ISO 630:1980, *Structural steels.*

ISO 1181:1990, *Ropes — Manila and sisal — Specification.*

ISO 1346:1990, *Ropes — Polypropylene — Specification.*

ISO 1459:1973, *Metallic coatings — Protection against corrosion by hot dip galvanizing — Guiding principles.*

ISO 1460:1992, *Metallic coatings — Hot dip galvanized coatings on ferrous materials — Gravimetric determination of the mass per unit area.*

ISO 1461:1973, *Metallic coatings — Hot dip galvanized coatings on fabricated ferrous products — Requirements.*

ISO 2408:1985, *Steel wire ropes for general purposes — Characteristics.*

ISO 3799:1976, *Textile machinery and accessories — Hydraulic lubricating fittings for textile machinery.*

ISO 6361-2:1990, *Wrought aluminium and aluminium alloy sheets, strips and plates — Part 2: Mechanical properties.*

ISO 6362-2:1990, *Wrought aluminium and aluminium alloy extruded rods/bars, tubes and profiles — Part 2: Mechanical properties.*

3 Definitions

For the purposes of this International Standard, the following definitions apply.

3.1 gangway: Bridge structure to allow safe embarkation and disembarkation from ship to shore or access to another ship.

3.2 side stringer: Longitudinal-strength member of the gangway to which the cross-members, stanchions, roller or wheels and the lifting lugs, etc. are attached.

3.3 cross-member: Part that holds the side stringer in position, and provides support for the decking.

3.4 decking: Flat-topped corrugated section or plate serving as the gangway floor.

3.5 tread: Batten fitted proud of the decking or deck plate level to give better foot grip when the gangway is inclined from the horizontal position.

3.6 guard rail: Hand and intermediate guide, supported by stanchions, to prevent people falling from the gangway.

4 Dimensions

The dimensions of an aluminium shore gangway shall be in accordance with figure 1. The minimum overall length, l , shall be 2 m, with optional increments of approximately 0,5 m up to a length of 9 m. For gangways longer than 9 m, the increments shall be approximately 1 m in length, until the desired overall length is attained.

5 Materials

The materials for aluminium gangway components shall comply with the requirements of table 1. Alternative materials may be used provided that they are at least as suitable in all respects for the intended duty and are equally acceptable to the purchaser.

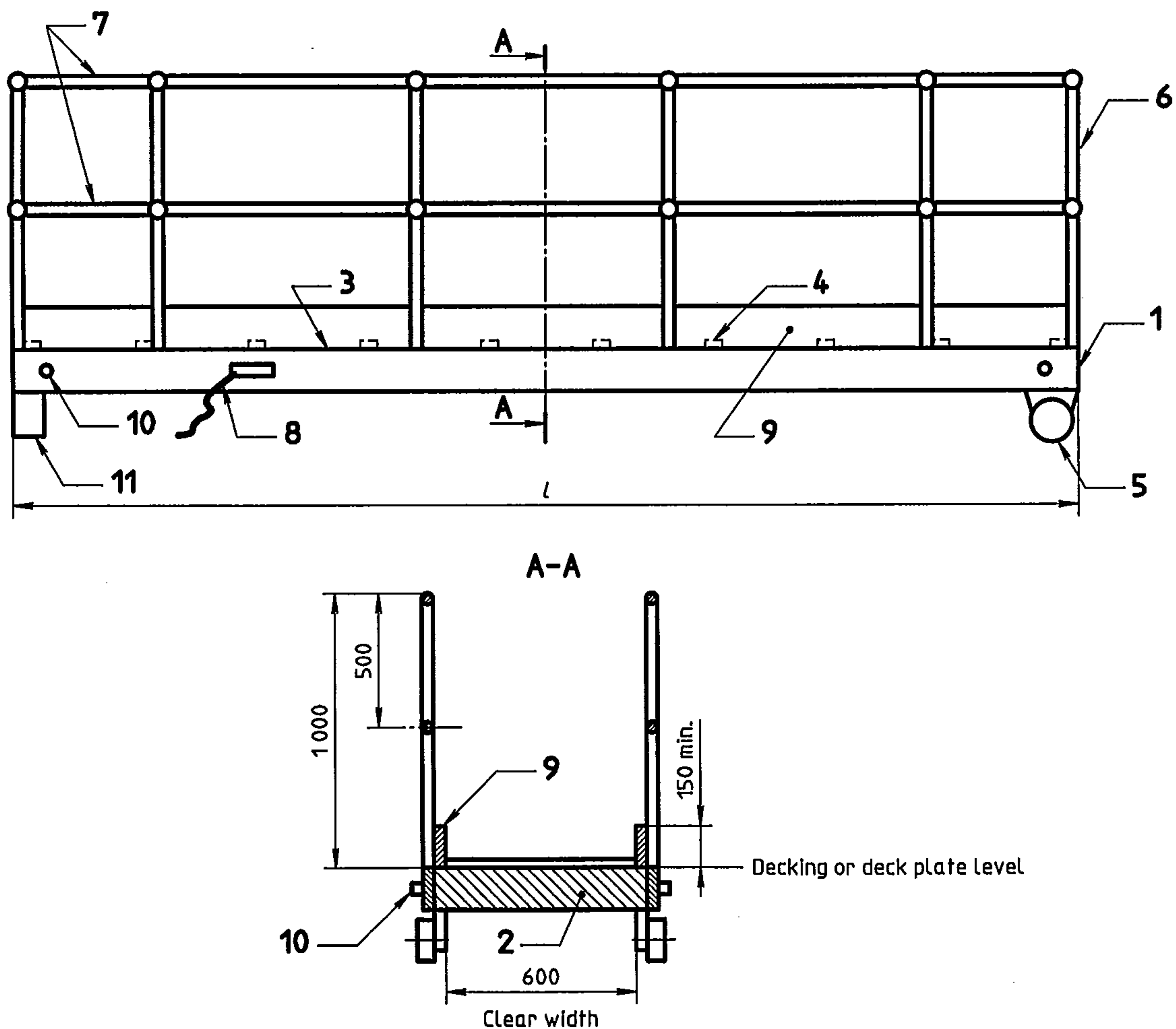

Figure 1 — General arrangement of a gangway (for item numbers, see table 1)

Table 1 — Materials

Item number¹⁾	Component	Material	ISO number	Remarks²⁾	
1	Side stringer	Aluminium alloy	ISO 209-1	Al Mg _{4,5} Mn _{0,7} (5083) Al SiMg(A) (6005 A)	
			ISO 6361-2 ISO 6362-2	Al MgSi (6060) Al Si1MgMn (6082)	
2	Cross-member	Aluminium alloy	ISO 209-1	Al SiMg(A) (6005 A) Al MgSi (6060)	
			ISO 6361-2 ISO 6362-2	Al Si1MgMn (6082)	
3	Decking or deck plate	Aluminium alloy	ISO 209-1	Al Mg _{4,5} Mn _{0,7} (5083) Al Mg ₃ (5754)	
			ISO 6361-2	Al Si1MgMn (6082)	
4	Tread	Aluminium alloy	ISO 209-1	Al Mg _{4,5} Mn _{0,7} (5083) Al Mg ₃ (5754) Al SiMg(A) (6005 A) Al MgSi (6060)	
			ISO 6362-2	Al Si1MgMn (6082)	
		I Hardwood	—	I e.g. oak	
5	Roller	I Carbon steel with rubber or plastics sleeve ³⁾	ISO 630	Grade Fe 430 (quality A)	
		Aluminium alloy	ISO 209-1	Al Mg _{4,5} Mn _{0,7} (5083) Al Mg ₃ (5754) Al SiMg(A) (6005 A) Al MgSi (6060)	
	Wheel	I Carbon steel with solid tyre of rubber or plastics ³⁾	ISO 630	Grade Fe 430 (quality A)	
6	Stanchion	Aluminium alloy	ISO 209-1	Al SiMg(A) (6005 A) Al MgSi (6060)	
			ISO 6362-2	Al Si1 MgMn (6082)	
		I Carbon steel	ISO 630	Grade Fe 430 (quality A)	
7	Guard rail	Rigid rail	Aluminium alloy	ISO 209-1	Al SiMg(A) (6005 A) Al MgSi (6060)
				ISO 6362-2	Al Si1MgMn (6082)
		I Sisal or manila		ISO 1181	
	Fibre rope	I Polypropylene monofilament or film rope	ISO 1346	See 6.9	
	Wire rope, plastics-coated	I PVC-coated guard-wire rope	ISO 2408	I Plastics-coated	

Item number ¹⁾	Component	Material	ISO number	Remarks ²⁾
8	Securing device	Sisal or manila rope	ISO 1181	
		Polypropylene monofilament or film rope	ISO 1346	See 6.12
9	Toeboard	Aluminium alloy	ISO 209-1	Al Mg _{4,5} Mn _{0,7} (5083) Al Mg ₃ (5754) Al SiMg(A) (6005 A)
			ISO 6361-2 ISO 6362-2	Al MgSi (6060) Al Si ₁ MgMn (6082)
		Hardwood		e.g. oak
10	Lifting lug	Aluminium alloy	ISO 209-1	Al Mg _{4,5} Mn _{0,7} (5083) Al SiMg(A) (6005 A)
			ISO 6361-2 ISO 6362-2	Al MgSi (6060) Al Si ₁ MgMn (6082)
11	Anti-slip lug	Aluminium alloy	ISO 209-1 ISO 6361-2	Al Mg _{4,5} Mn _{0,7} (5083) Al Si ₁ MgMn (6082)
<p>1) The item numbers in this table refer to component parts in figure 91.</p> <p>2) The numbers in parentheses are taken from the <i>Registration Record of International Alloy Designations and Chemical Composition Limits for Wrought Aluminum and Wrought Aluminum Alloys</i> (revised edition 1987), published by the Aluminum Association, Washington, DC., USA.</p> <p>3) The sleeve or tyre may have a ribbed or flat surface.</p>				

6 Design and construction

6.1 General design features

6.1.1 The manufacturer of the gangway shall be informed of any unusual or hazardous conditions affecting the criteria for design of the gangway.

6.1.2 Direct contact between dissimilar metals shall be avoided to prevent galvanic corrosion.

6.1.3 If the gangway is for use on tankers or ships carrying flammable cargo, it shall be provided with an effective and marked earthing device, and shall be suitably surface-coated at the possible points of contact to prevent sparking.

6.2 Design loading

The assembled gangway shall be designed to withstand a uniform decking load of 4 000 N/m applied to the decking and treads while the gangway is in a horizontal position.

6.3 Factor of safety

The allowable stress used in the design of the gangway as specified in 6.2 shall be determined by applying a factor of safety of 2 on the 0,2 % proof stress ($R_{p0,2}$) of the aluminium alloy used.

6.4 Side stringers

Side stringers shall be constructed from extruded hollow section, rolled section, plate material or any combination of these.

6.5 Cross-members

Cross-members attached to the side stringers shall be arranged to support the decking, and shall be of bar, angle or hollow sections.

6.6 Decking

The decking shall comprise either continuous flat-topped longitudinal corrugated section, or individual flat plate section, which shall have a non-slip coating applied between the treads.

6.7 Treads

Treads shall be of aluminium bar or rectangular hollow section, or of hardwood, and shall be spaced at regular intervals of 300 mm to 400 mm longitudinally.

Treads shall have a minimum height of 30 mm above the decking; hardwood treads shall have a minimum section width of 40 mm in contact with the decking.

All treads shall be securely fitted, and shall extend over the full width of the gangway between the toeboards. Provision should be made for easy clean-

ing of the gangway between the treads, by leaving a 25 mm space between tread and toeboard at each side. Water shall not gather between the treads.

6.8 Stanchions

Stanchions shall be constructed from carbon steel or aluminium to comply with figure 1. They shall be fitted at regular intervals along the gangway, with a maximum permitted interval of 1 500 mm. Stanchions and associated hand guides shall be designed for a side loading at the upper guide level of 500 N/m, without permanent deformation to stanchions or rigid hand guides when used. Stanchions of one of the following types may be fitted:

- a) permanently fixed;
- b) hinged, with provision made to prevent inadvertent collapse;
- c) portable, with securing device to prevent accidental displacement from the socket or base support.

Galvanized stanchions, where specified, shall comply with the requirements of ISO 1459, ISO 1460 and ISO 1461.

6.9 Hand and intermediate guides

Hand and intermediate guides shall be provided to comply with figure 1 and shall be selected from one of the following types:

- a) continuous and adequately tensioned sisal, manila, polypropylene or plastics-covered wire rope, having a minimum rope diameter of 16 mm;
- b) continuous rigid aluminium solid or hollow section.

In case of fibre rope or wire rope rails, a way to re-tighten such rails should be provided.

Polypropylene ropes shall be certified effective against actinic degradation for two years exposure in tropical conditions.

6.10 Toeboards

Toeboards shall be fitted to each side of the gangway to a minimum height of 150 mm.

6.11 Roller or wheels

A roller or wheels of 100 mm minimum outside diameter shall be positioned at one end of the gangway. Rollers and wheels shall be provided with self-lubricated bearings or fitted with lubrication nipples to ISO 3799 specifications having a thread M10 x 1. To

ensure protection of users' feet from movement of the gangway, roller or wheel guards shall be provided. At the maximum angle of use of the gangway there shall be no loss of contact between the roller or wheels and the contact surface.

6.12 Securing device attachments

Suitable attachments shall be provided at appropriate points on both sides of the gangway, in order to connect the securing devices (see figure 1).

6.13 Lifting lugs

The gangway shall be provided with four lifting lugs, securely attached to the side stringers and positioned to produce a balanced lift.

6.14 Anti-slip lugs

The gangway shall be provided with anti-slip lugs securely attached to the side stringers, and positioned to prevent the gangway slipping from its position on the bulwarks or other supporting structure.

6.15 Protection against corrosion and rot

Steel parts of the gangway shall be provided with anti-corrosion coatings. If contact of dissimilar metals cannot be avoided, the surface of contact shall be protected particularly carefully.

Wooden parts of the gangway shall be suitably protected against rot and fungi.

6.16 Rope net

In some countries, a safety net is required: in these cases, it shall be spread underneath the gangway.

7 Quality of manufacture

7.1 The assembly, comprising side stringers, cross-members and decking, together with all ancillary fittings, shall be visibly free from defects and distortion.

7.2 All components shall be free from exposed rough or sharp edges likely to cause injury.

7.3 Care shall be taken in the preparation, riveting, bolting or welding of aluminium structures to ensure that the permissible design stresses are not exceeded.

8 Acceptance tests

The following tests shall be carried out at the manufacturer's works.

8.1 Type test

One gangway of the longest design length for each stringer type shall be tested by the methods given below and a test certificate made available to the purchaser on request.

The deflection due to loading (according to 6.2) shall not exceed the value of the overall length divided by 75.

Each gangway submitted for type test shall be fully assembled with all fittings and subjected to the tests given in 8.3.1 to 8.3.3.

8.2 Individual test

Individual gangways manufactured to a design which has been satisfactorily type-tested in accordance with 8.1 shall be subjected to the tests given in 8.3.1 and 8.3.2, if requested by the purchaser.

8.3 Test methods

8.3.1 Lifting

Lift the gangway by means of the lifting lugs provided. After the test there shall be no evidence of strain to the lugs or the adjacent structure.

8.3.2 Initial sag

Initial sag, Y , is determined as follows:

Place the gangway horizontally on supports positioned at one end under the roller or wheels and at the other end close to the anti-slip lug (see figure 1). The gangway shall be fully assembled with all fittings, comprising the dead load. Stretch a thin string or wire tightly between the two support points. Then measure the maximum vertical distance appearing between the horizontal line and the base of the gangway. This measurement shall be taken for both side stringers.

The average of the two readings Y_1 and Y_2 for initial sag is taken as:

In the case of individual testing, the initial sag shall not be greater than that recorded for the type test.

8.3.3 Deflection under load

With the gangway still supported as in 8.3.2, carry out the deflection test immediately after the results of initial sag are determined. Apply, without shock, a uniform load equivalent to 5 000 N/m² to the longitudinal centreline of the decking. The load shall be arranged from a selection of conveniently sized

sandbags or other material that will not damage the gangway, and located at equally spaced intervals of not more than 1 m. Where the design incorporates individual decking plates, apply a load equivalent to 5 000 N/m² to each plate. Maintain the test load for 15 min before the total deflection of the gangway at each side stringer is measured.

The maximum deflection for each side stringer shall be measured as the maximum vertical distance between the string or wire stretched tightly between the support points and the base of the gangway. The average of the two readings Y'_1 and Y'_2 is taken as the total deflection Y_T :

$$Y_T = \frac{Y'_1 + Y'_2}{2}$$

The deflection due to loading ΔY shall be calculated by subtracting the initial sag from the total deflection as follows:

$$\Delta Y = Y_T - Y$$

9 Marking

Each gangway shall be permanently marked by means of a rating plate prominently displayed. The rating plate shall contain information relevant to the gangway, including the following:

- manufacturer's name or trademark;
- type number and serial number;
- number of this International Standard (ISO 7061);
- overall length;
- maximum permitted angle of inclination;
- design loading.

10 Inspection

10.1 Gangways subjected to a type test shall be inspected after testing to ensure that there are no signs of residual weakness or damage.

10.2 All gangways shall be visually checked after testing to ensure that:

- there is no distortion of the side stringers;
- the decking or deck plates are adequately secured;
- the roller or wheels revolve freely;
- if applicable, the stanchions, hand and intermediate guides can be easily erected in position;

- e) removable fittings for rigid joints can be properly stowed when the gangway is dismantled;
- f) the rating plate is affixed and correct.

11 Designation

A gangway conforming to this International Standard shall be designated as follows, in the order given:

- a) description: gangway;
- b) number of this International Standard: ISO 7061;

- c) overall length, in metres;
- d) maximum permitted angle of inclination, in degrees.

EXAMPLE

The designation of an aluminium shore gangway of overall length 9 m, limited to 30° angle of inclination, is:

Gangway ISO 7061 - 9 - 30

UDC 629.12.011.57

Descriptors: shipbuilding, embarkation devices, aluminium products, gangways, specifications, dimensions, construction, tests, designation, marking.

Price based on 7 pages